

Application guideline for exhibitions (Small and Book/Catalog booth)

1. Specification of exhibitions (Small and Book/Catalog booth)

(1) Number of booths (planned)

Type of booth	Fee	Maximum number of booth
Small (W1800×D1200×H2100)	¥220,000 (tax incl.)	50
Medium* (W1800×D900)	¥55,000 (tax incl.)	6

※This is an exhibition booth where you can only display panels and desk catalogs, and there is no need to dispatch explanation staff, but each company is responsible for preparing panels, displaying catalogs, and replenishing them.

(2) Venue : Tsukuba International Congress Center, Large Conference Room 102 (planned)

(3) Basic specifications (planned) (Excluding book/catalog booth)

Exhibition desk size: W1800 mm×D600 mm×H700 mm×2

Panel size: W1800 mm×H2100 mm

Company name plate: W900 mm×H300 mm (black / English notation of corporation is unified by Co., Ltd.)

Power outlet: 1 outlet, 500W (Power supply exceeding 500W will be charged separately)

Clip light: 2 lights

※The organizer will decide the allocation of booth place, carry-in/carry-out time, exhibition time, after the application deadlines.

※If you wish to use the power supply and special decoration, you need to apply for options separately.

Details will be announced after the application deadline.

【Conceptual drawing】

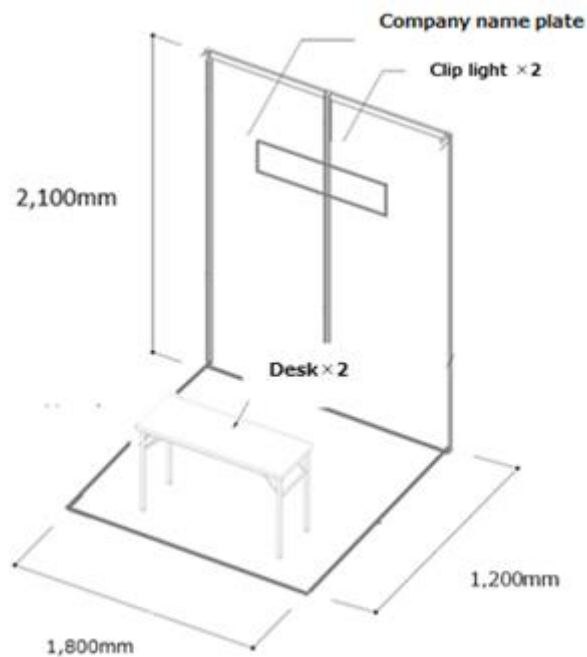

(2) Application method

(1) Application method :

Please fill out the "Exhibition Application Form" and send it by e-mail or fax. The exhibition application form can also be downloaded from the lecture website.

(2) Place for application :

The JSM 77th Annual Meeting Management Office, JTB Ibaraki Minami Branch
Takezono 2-2-4, the 2nd ISSEI building 3F
TEL: 029-860-2872 FAX: 029-854-1664
E-mail : mice-tsukuba@jtb.com

(3) Application deadlines : **March 12, 2021 (Friday)**

- * Space is limited, so the deadline will be closed as soon as it is full.
- * If the planned number of exhibition booths is not reached, the application deadline may be extended, so please contact the above secretariat.
- * We will send you an invoice after the application deadline.

* Please pay the transfer fee.

* We will replace the receipt issued by the bank with our receipt.

(4) Cancellation policy : It cannot be canceled unless the organizer finds it to be force majeure. If you must cancel the exhibition or change the contents, please submit a document stating the reason and obtain approval.

In case of cancellation of application due to exhibitor's convenience, the following cancellation fee will be charged;

50% of the application fee until March 12, 2021 (Friday)

100% of the application fee / No Refund after March 13, 2021 (Saturday).

* If it becomes difficult to hold an exhibition due to force majeure such as natural disasters and infectious diseases, we will refund after deducting the expenses already incurred at that time. If you have not paid, we will issue an invoice for expenses that have already been incurred at that time.

(5) Others : Please note that the exhibitor is responsible for the management of each exhibitor, and the organizer is not responsible for any theft, loss, damage, etc., including compensation.

1 participation certificates and 1 printed proceedings will be given to the companies that cooperated with the exhibition.

(There is no invitation to the social gathering)

FAX destination : 029-854-1664 or
 E-mail destination : mice-tsukuba@jtb.com
 (To the JSM 77th Annual Meeting Management Office)

Deadlines for applications : March 12, 2021

Exhibition booth (Small and Book/Catalog) application form

Date : Month /Day /Year

1. Name of applicant

Company			
Department			
person in charge			
Address	〒/Postal code		
	※Invoices will be sent to the above address and the person in charge.		
TEL		FAX	
E-mail			

2. Specifications request ※Please enter the desired number of booths

desired number of booths	Small booth () ※¥220,000 (tax incl.) /booth Book/catalog booth () ※¥55,000 (tax incl.) /booth
Electric power	<input type="checkbox"/> Not required <input type="checkbox"/> 100V Power () W <input type="checkbox"/> 200V (Single-phase · Three-phase) Power () W ※Power supply exceeding 500W will be charged separately
Special decoration	No / Yes

3. Contents of exhibition(s)

Please specify the exhibit items. (Product name, quantity, weight, etc.)

4. Contact information

The JSM 77th Annual Meeting Management Office, JTB Ibaraki Minami Branch

Takezono 2-2-4, the 2nd ISSEI building 3F

TEL: 029-860-2872 FAX: 029-854-1664

E-mail : mice-tsukuba@jtb.com